

**SUMMIT**  
MACHINE TOOL LLC

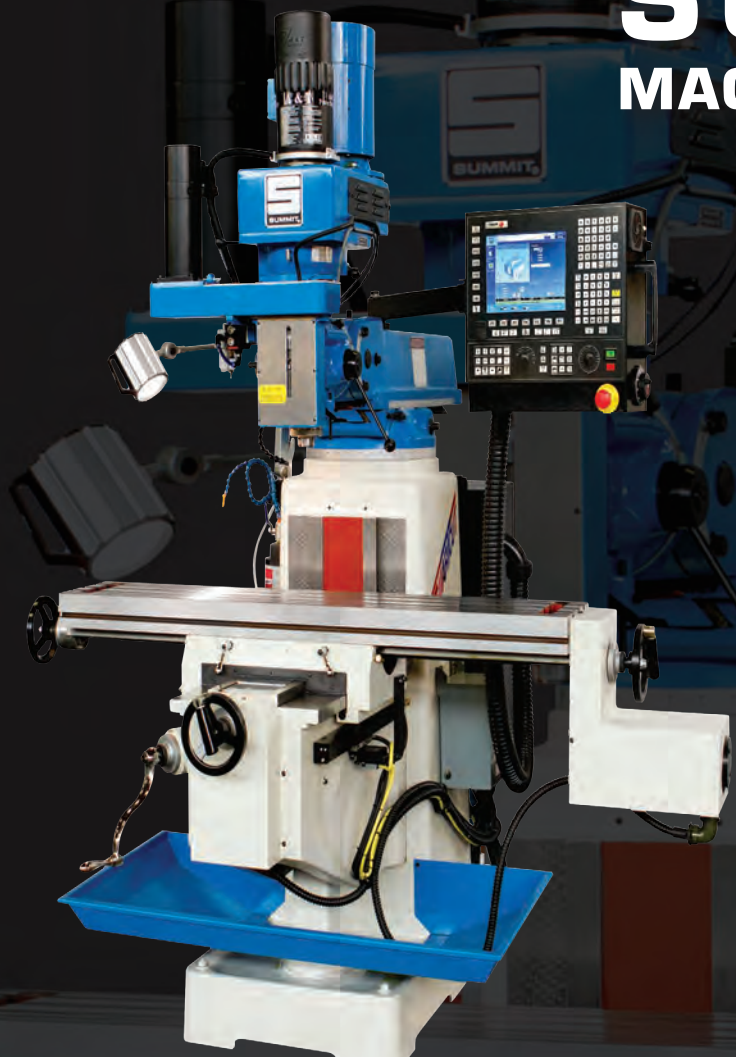

MODEL SC EVS-350B



MODEL SC EVS-550B

# SMARTCUT EVS SERIES CNC VERTICAL MILLS

SC EVS-350B & SC EVS-550B

# SMARTCUT EVS SERIES

---

## SUMMIT SMARTCUT EVS SERIES CNC MILLS

**SmartCut EVS** is a new series of CNC Mills available from Summit Machine Tool LLC. The SmartCut EVS CNC is everything you expect, rugged and dependable with the precision needed for high tolerance applications. It combines Summit's 50+ year history of providing "the most machine for the money" and the Fagor 8058 CNC control to provide another winning solution for your manufacturing needs.

The **SmartCut EVS CNC** standard Fagor 8058 controller is a user friendly conversational CNC that offers powerful and versatile programming features. Because of its outstanding capabilities, set up time is minimized for both experienced and novice operators. The extensive use of graphics at the programming screens means that even complex machining tasks are easily dealt with, only the minimum of numerical data entry being required.

The **SmartCut Series** was designed for growing companies evolving from manual mill operations to CNC and more sophisticated users who want a simple easy to use machine. The control language is conversational or G-code, with on-screen menus and prompts to make programming virtually foolproof. The Fagor 8058 control is equipped with multiple ports for connection to off-line programming systems for more advanced users.

The **SmartCut EVS** series is a perfect fit for every application from small one man operations to job shops, R&D departments, tool room and maintenance shops as well as large manufacturing operations.

## KEY FEATURES & BENEFITS

- Inverter duty, high energy - high efficiency motors for lower utility costs, save up to 35%
- Fewer moving parts in the head for less maintenance and down time
- Continuous cooling to the spindle motor even at low RPMs
- Centrally-located controls for ease of operation
- Immediate response spindle speed control (0-full speed in 3 sec.)
- Full range RPM selection. Tweak up or down to prevent chatter and prolong tool life
- Electronic inverter controlled braking for reduced set-up time
- "Turcite-B" inserted guideways for extended machine life
- Complete electrics with low voltage controls for safer machine operation
- Compact AC frequency inverter spindle drive
- Fan cooled electrical enclosure
- Heavy "Meehanite®" cast iron construction for excellent damping
- Huge box ways on knee
- Built in coolant system
- Power knee (SC EVS-550B)
- Power draw bar (SC EVS-550B)
- Automatic lubrication
- Safety handles on table and saddle
- Fagor glass scale feed back
- Precision ground ball screws with double nut design
- Spindle speed controlled through the CNC

# SMARTCUT EVS-SERIES CNC MILLS SC EVS -350B & SC EVS-550B

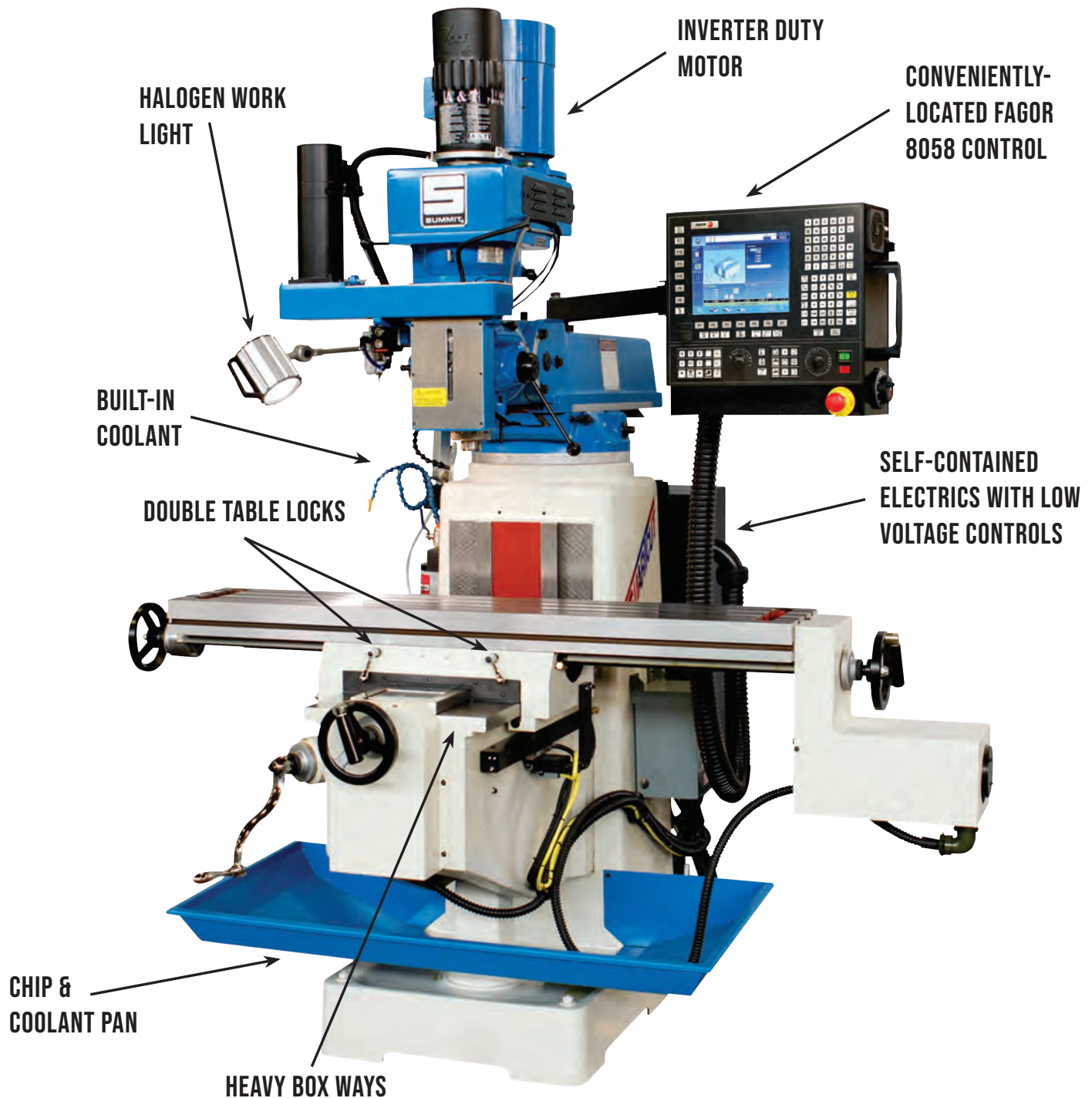

## INCLUDED ACCESSORIES

- Oil Gun
- Screw Drivers
- Chip & Coolant Pan
- Draw Bar
- Power Draw Bar (SC EVS-550B)
- Open End Wrench Set
- Box End Wrench Set
- Hex Key Set
- Clamping Kit
- R-8 Collet Set (SC EVS-350B)
- Way Covers
- Halogen Work Light
- Power Knee (SC EVS-550B)

# FAGOR CNC 8058 CONTROL FEATURES

The Fagor 8058 Control System is perhaps the most versatile CNC in existence due to its Dual Operating System. In one mode, it is a very powerful ISO G-code control system and in the other mode, icon conversational programming with highly interactive graphics. This makes even complex tasks easy to program - regardless of the operators' experience level.

## Features:

- High level conversational and full G code programming.
- 10.4" High Resolution LCD color monitor
- Linear, Circular and Helical Interpolation
- Tool Radius & Length compensation, 255 offsets
- Simulation dry run mode & HD Solid Graphics 3D with zoom
- Jog Mode & MDI Mode
- Tool offset and Zero offset tables
- Free Simulator for PC offline software program
- G-codes & M-Functions online
- Ethernet TCP/IP

## Versatility:

- It is a motion controller when performing semi-automatic operations
- It is a full-powered CNC control for automatic operation

## Ease of operation:

- Operations defined by symbol keys
- Interactive graphic data entry
- Fully automatic operating modes

## Profitability:

- Inspection mode with auto-return
- Background editing mode
- Automatic tool calibration mode



## 26 Total Cycles Including:

- Icon Conversational Programming
- Rectangular Boss cycle
- Round Boss cycle
- Rectangular Pocket cycle
- Circular Pocket cycles
- Profile Pocket 2D & 3D cycles
- Slot Milling
- Profile Milling
- Multiple Drilling cycles
- Boring cycles
- Reaming cycles
- Arc Bolt Hole cycles
- Random Position cycles
- Grid Pattern cycles.



## AXIS SERVO DRIVES

All SmartCut models are designed with ruggedness in mind. They are fitted with independent servos on each axis. These servos are sized to allow maximum material removal while providing the quick response necessary for smooth transition while doing simultaneous cuts. Distance coded linear scales provide positioning feedback information to the control.



## ELECTRONIC VARIABLE SPEED HEAD

The SmartCut EVS Series CNC Mills feature an electronic variable speed head that is designed to be virtually trouble free. The use of a frequency inverter eliminates many of the normal wear parts found in mechanical variable speed designs. The spindle speed is programmable through the CNC control with over-ride capability.

## ELECTRICAL EQUIPMENT

The SmartCut EVS CNC Series mills incorporate state-of-the-art electrics inside a Nema-type enclosure. All components are U/L listed. DC servo axis drives and a frequency inverter spindle drive are used to compliment the Fagor control. The electrical cabinet features forced air cooling and is designed with a safety interlock to prevent machine operation when open.

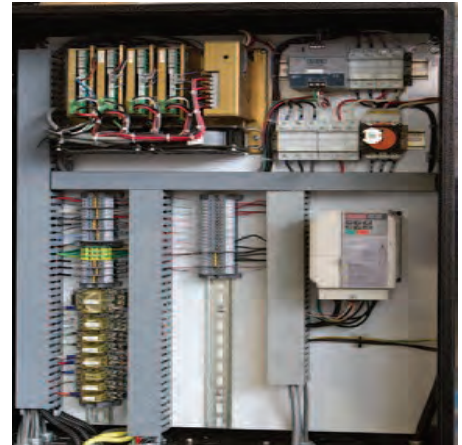

## SPINDLE PACKAGE

With the addition of the Spindle Ballscrew and Motor the Summit SmartCut EVS CNC Mills are transformed into a full 3 Axis CNC controlled Milling Machine. This provides the ability to perform all types of contour (3D) milling operations as well as drilling complex hole patterns automatically.

This feature can also be disabled and the quill can be hand operated should the operator prefer. (SC EVS-350B only)

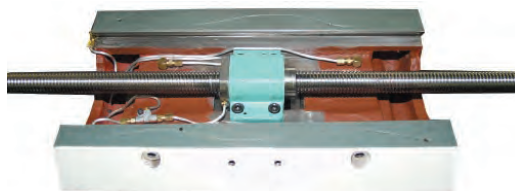

## CONSTRUCTION

The SmartCut mills are constructed of high grade Meehenite™ alloyed cast iron, normalized and aged to achieve maximum stability. The design features heavy cross ribbing for rigidity and vibration dampening. Ways are hardened (HRC 48-56), precision ground and mated to Turcite-B coated guideways for accuracy and long life.

# SPECIFICATIONS SMARTCUT EVS-SERIES CNC MILLS

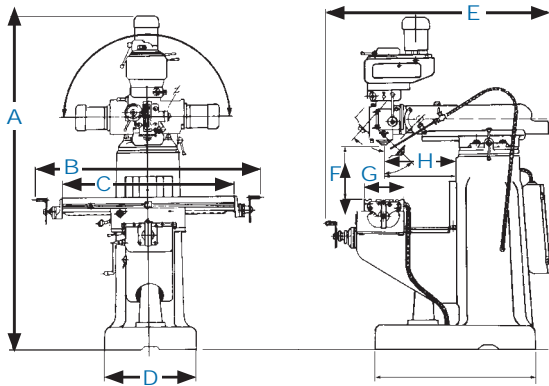

VERTICAL MILL DIMENSIONS		
	SC EVS-350B CNC	SC EVS-550B CNC
A	92" / 2340mm	100" / 2540mm
B	67" / 1700mm	69" / 1750mm
C	54" / 1370mm	52" / 1320mm
D	24" / 600mm	24" / 600mm
E	78" / 1980mm	80" / 2030mm
F	0-18.5" / 0-470mm	0-22" / 560mm
G	10" / 250mm	11" / 280mm
H	4.25" - 26.25" 110 - 670mm	8" - 32" 200mm - 810mm

SPECIFICATIONS	SC EVS-350B CNC		SC EVS-550B CNC	
	INCH	METRIC	INCH	METRIC
<b>HEADSTOCK</b>				
<b>Motor Sizes (2 Speeds)</b>	3 HP	2 kw	5 HP	3.5 kw
<b>Spindle Speeds - Number</b>	Infinitely Variable		Infinitely Variable	
<b>Spindle Speeds - Range (RPM)</b>	0 - 4300		0 - 3650	
<b>Spindle Taper</b>	R-8		#40	
<b>Spindle Travel</b>	5"	125mm	5.5"	140mm
<b>Head Movement - Side to Side</b>	±90°		N/A	
<b>Head Movement - Front to Back</b>	±45°		N/A	
<b>TABLE</b>				
<b>Table Size (W x L x H)</b>	10" x 54" x 3 1/8" 225 x 1370 x 80mm		11" x 52" x 3 1/8" 280 x 1370 x 80mm	
<b>Table Feed (longitudinal)</b>	34"	915mm	32"	825mm
<b>Table Feed (cross)</b>	14"	405mm	14"	405mm
<b>Maximum Weight of Workpiece</b>	850 lbs.	386 kg	1,025 lbs	466 kg
<b>OVERARM</b>				
<b>Rotation of Overarm</b>	360°		360°	
<b>Overarm adjustment</b>	22"	560mm	24"	610mm
<b>Spindle Nose to Table</b>	2.5" - 18.5"	65 - 445mm	3" - 20"	80 - 510mm

**WARRANTY:** A copy of Summit Machine Tool LLC's standard written warranty is attached to each Summit Machine. Call or write to Summit for a copy or for further information concerning Summit's standard warranty. All purchases are subject to Summit's standard written warranty. Specifications are subject to change without notice.

**POINT OF OPERATION GUARDING** is the responsibility of the end user. For information contact your local OSHA office.

## SUMMIT MACHINE TOOL LLC

518 N Indiana Ave • Oklahoma City, OK 73106

MAIN 405.235.2075

FAX 405.232.5169



FOR MORE INFORMATION CALL 1-800-654-3262

[WWW.SUMMITMACHINETOOL.COM](http://WWW.SUMMITMACHINETOOL.COM)