

**Summit Machine  
Tool Manufacturing  
L.L.C.**

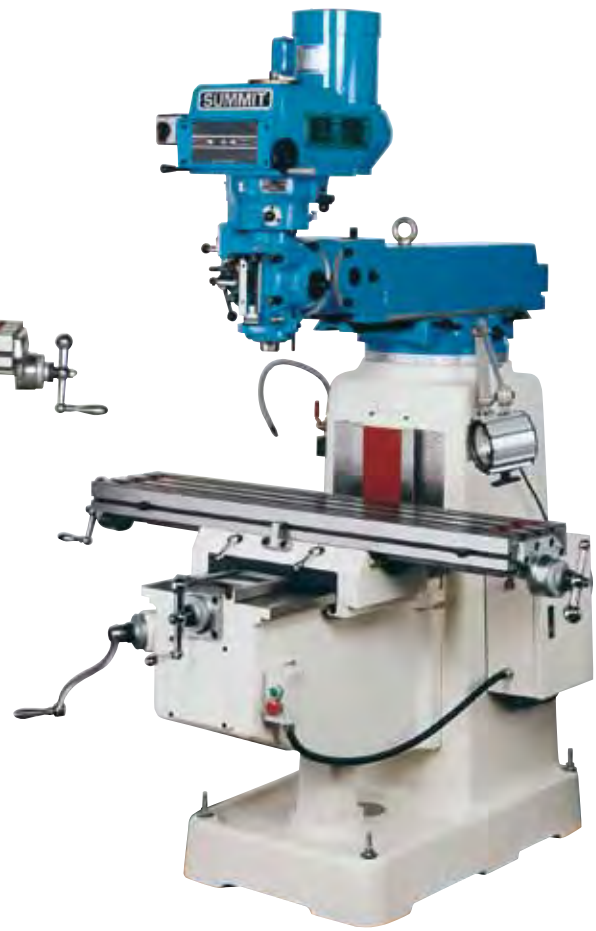

## **Vertical Mills**

**V-242B  
VS-350B  
VS-550B  
EVS-349B  
EVS-350B  
EVS-550B**



### Column

The heavy one-piece base and column is a thick walled Meehanite casting that is fully cross-ribbed for strength and rigidity. The built-in coolant tank is another added value feature of the heavy duty base and column.



### Knee and table assembly

The oversized knee, with its large ratio of length to width, provides extra support for the table and saddle for large workpieces and heavy cuts. The precision ground table is provided with three T-slots for easy workpiece clamping.

The rugged **Summit V-Series** vertical mills have been engineered and manufactured from the finest components with the operator in mind. All the controls are centralized for ease of operation in either hand or power feed mode. Movement of the head to various angles is easily obtained from the operator's position.

Available in six models to give you the choice that fits your machining requirements the best. The **V-242B**, a two horsepower, step pulley model for the budget minded; the **VS-350B**, a three horsepower model with standard variable speed that is a real workhorse; the **EVS-349B** and **EVS-350B** are three horsepower models with Electronic Variable Speed for the utmost control; the **VS-550B**, a massive five horsepower model with standard variable speed or the top of the line **EVS550B**, five horsepower Electronic Variable Speed model that provides instant speed control coupled with the brute strength and stability for heavy cuts and fine finishes in all types of materials.

### INCLUDED ACCESSORIES

- Oil gun
- Screw drivers
- Way covers
- Clamping kit
- Box end wrench set
- (6) R-8 collets (V242B, VS350B, EVS349B & EVS350B)
- Halogen work light
- Built-in coolant system
- Dual voltage 220/440
- Open end wrench set
- Hex key wrench set

### OPTIONAL EQUIPMENT

- 2 axis electronic digital readouts (X & Y)
- 3 axis electronic digital readouts (X, Y, knee or quill)
- Longitudinal (X-axis) power feed
- Cross (Y-axis) power feed
- Knee (Z-axis) power feed (V242B, VS350B, EVS349B & EVS350B)
- Power draw bar (V242B, VS350B, EVS349B & EVS350B)
- 40 taper end mill holders (VS550B & EVS550B)
- Drill chuck with arbor
- Milling machine vise
- 12" rotary table
- 6" riser block

# Standard Features

## V-242B STEP PULLEY

- Heavy Meehanite cast construction
- Double table locks
- Way wipers for saddle & column
- Hardened & ground ways
- Hand & power spindle feeds
- Tilting and rotating head
- One-shot lubrication
- Low voltage controls
- Step pulley head
- Dovetail ways

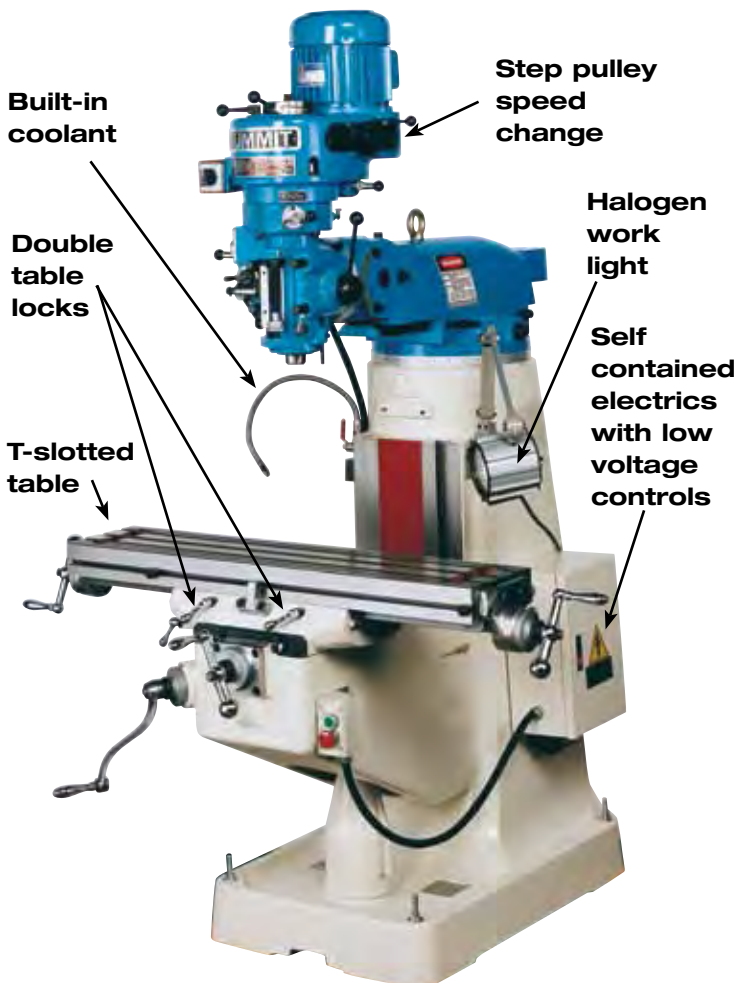

## VS-350B STANDARD VARIABLE SPEED

- Heavy Meehanite cast construction
- Heavy box saddle
- Huge box type ways on knee
- Double table locks
- Way wipers for saddle and column
- Hardened and ground ways
- Hand and power spindle feeds
- Tilting and rotating head
- One-shot lubrication
- Adjustable cross slide stops
- Low voltage controls
- Variable speed head

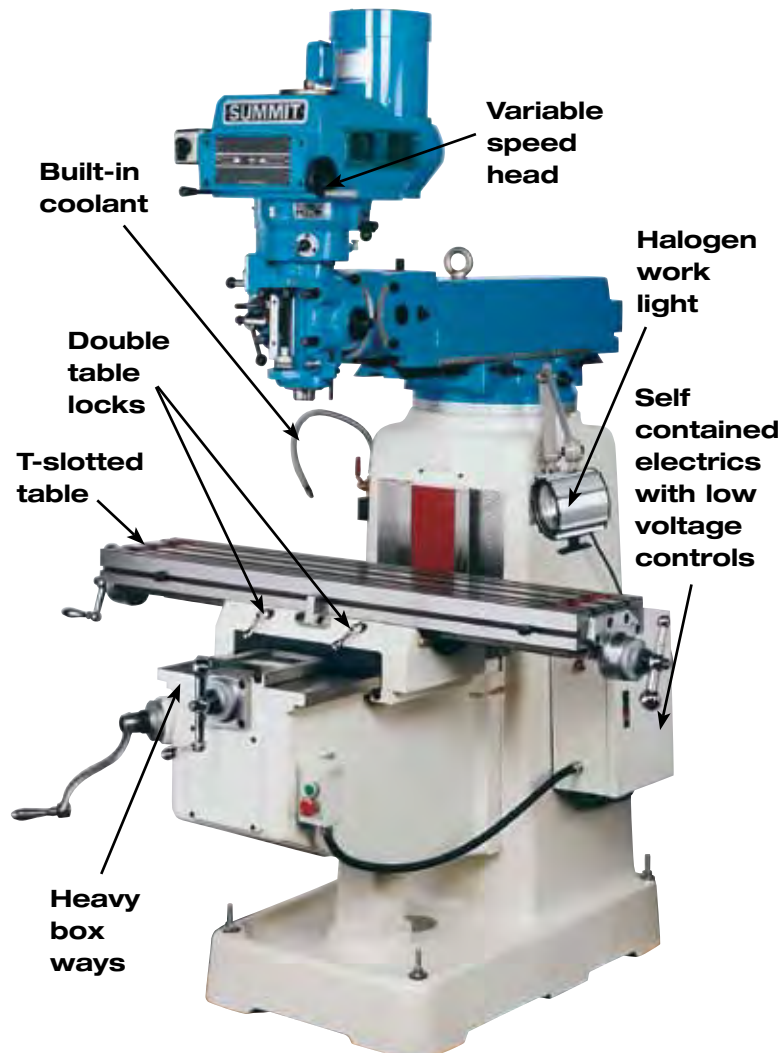

## VS-550B STANDARD VARIABLE SPEED

- Heavy Meehanite cast construction
- Double table locks
- Heavy box ways on the saddle, knee and column
- Hardened and ground ways
- Hand and power spindle feeds
- Rotating, variable speed head
- Power draw bar
- One-shot lubrication
- Complete electrics with low voltage controls
- Powered knee

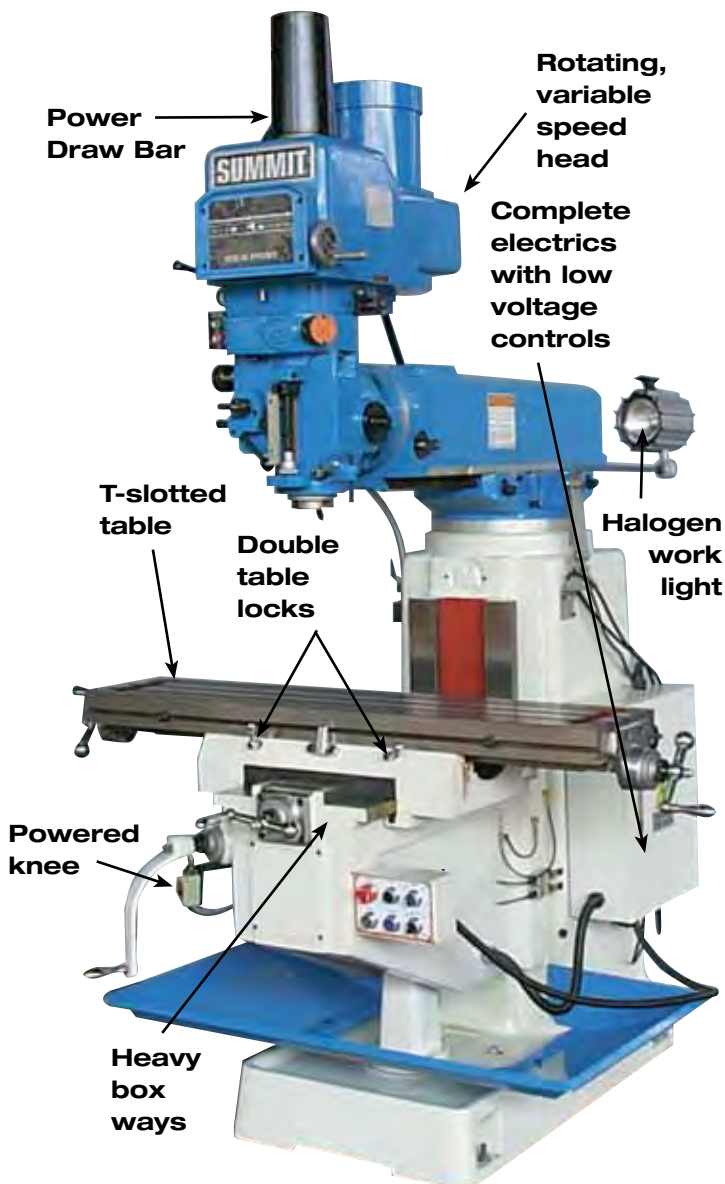

## EVS-349B ELECTRONIC VARIABLE SPEED

- Full 3HP with electronic variable speed
- Can be setup for 220v single or three phase
- No extra cost for 440v three phase
- Meehanite® castings
- Hardened and ground ways with Turcite® liners
- 9"x49" table
- Includes: coolant system, halogen worklight, complete electrics, clamp kit and collets

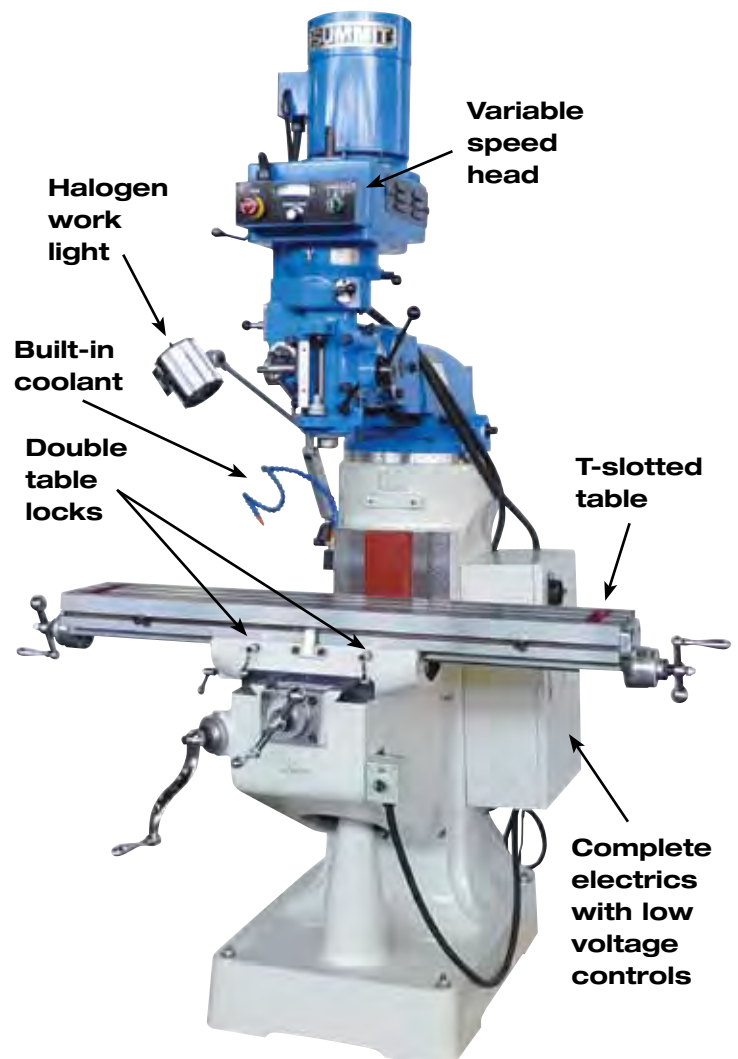



## EVS-350B & EVS-550B ELECTRONIC VARIABLE SPEED

- Inverter Duty, High Energy - High Efficiency Motors for lower utility costs, save up to 35%
- Fewer moving parts in the head for less maintenance and down time
- Cogged drive belt to prevent belt slippage and extend tool life
- Centrally located controls for ease of operation
- Immediate response speed control (0-full speed in 4 sec.)
- Full range RPM selection. Tweak up or down to prevent chatter and prolong tool life
- Electronic Inverter controlled braking for reduced set-up time
- "Turcite-B" inserted guideways for extended machine life
- Complete electrics with low voltage controls for safer machine operation
- Yaskawa compact AC inverter drive
- Fan cooled electrical enclosure
- Heavy "Meehanite®" cast iron construction for excellent damping
- Huge box ways on knee
- Powered knee (EVS550B)
- One shot lubrication
- Power draw bar (EVS550B)

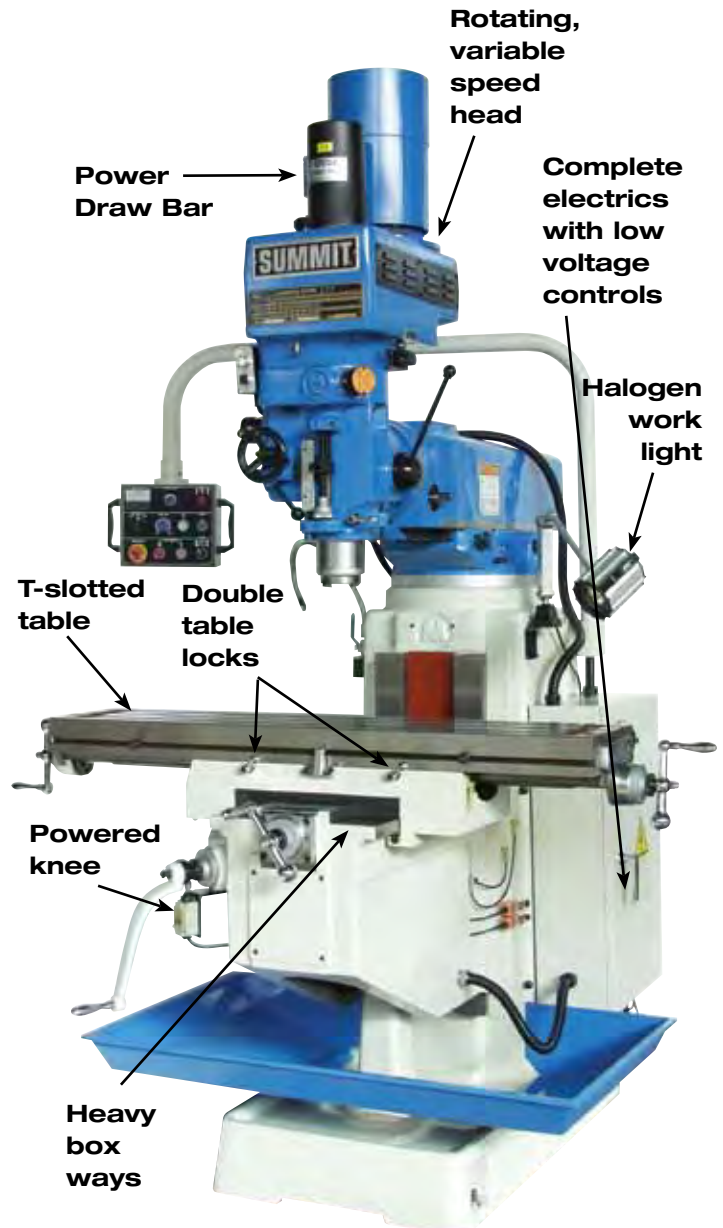
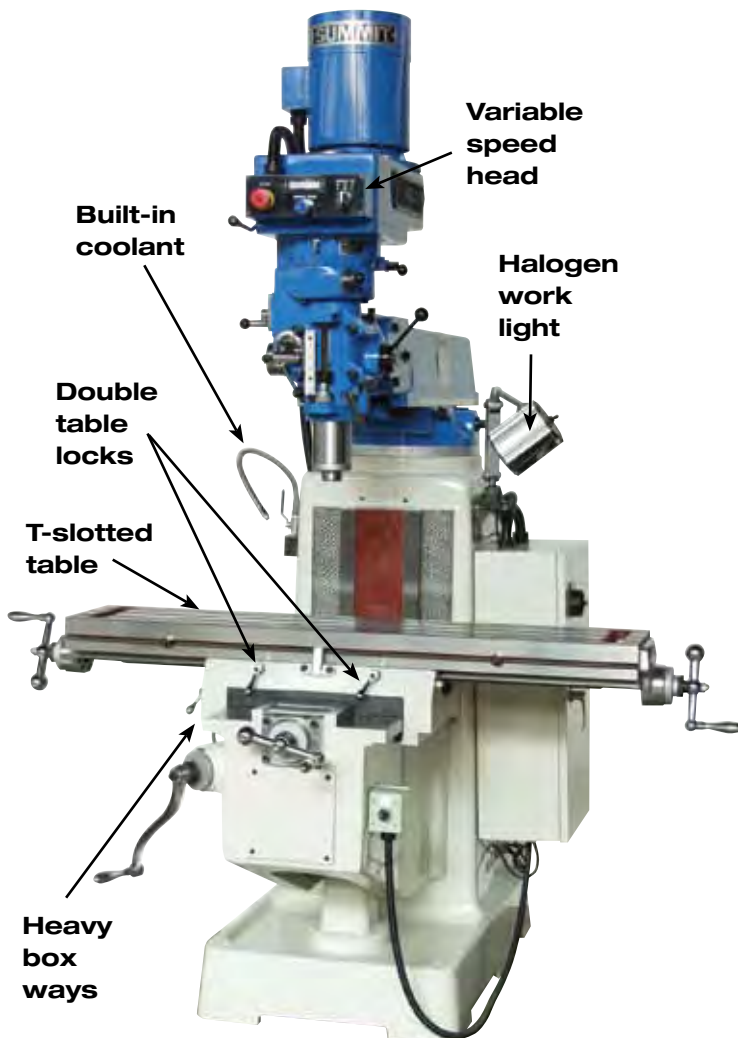

# Specifications V242B, VS350B, VS550B, EVS 349B, EVS350B & EVS550B Vertical Mills

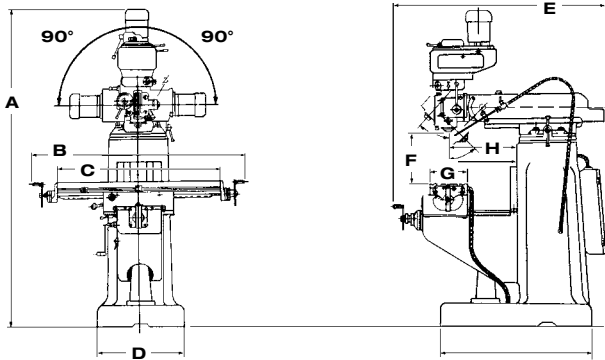

## Vertical Mill Dimensions

	V-242B	VS-350B	VS-550B	EVS-349B	EVS-350B	EVS-550B
<b>A</b>	82 3/16"	92"	100"	88"	92"	101"
<b>B</b>	59"	67"	69"	66"	67"	69"
<b>C</b>	43.68"	50"	52"	50.7"	50"	52"
<b>D</b>	24"	24"	24"	24"	24"	24"
<b>E</b>	78"	78"	80"	78"	78"	80"
<b>F</b>	0-16"	0-18.5"	0-22"	0-17.5"	0-18.5"	0-22"
<b>G</b>	9"	10"	11"	9"	10"	11"
<b>H</b>	4 1/4"-21 1/2"	6 1/4"-28 1/4"	8"-32"	4.25"-19.25"	6 1/4"-28 1/4"	8"-32"

SPECIFICATIONS	V-242B		VS-350B		VS-550B		EVS-349B		EVS-350B		EVS-550B	
	Inch	Metric	Inch	Metric	Inch	Metric	Inch	Metric	Inch	Metric	Inch	Metric
<b>HEADSTOCK</b>												
Motor size (2 speeds)	2 H.P.	1.5 kw	3 H.P.	2 kw	5 H.P.	3.5 kw	3 H.P.	2 kw	3 H.P.	2 kw	5 H.P.	3.5 kw
Spindle speeds - number	16		Inf. variable		Inf. variable		Inf. variable		Inf. variable		Inf. variable	
Spindle speeds - range (RPM)	80 - 5440		60 - 4200		80-3500		0 - 4300		0 - 4300		0 - 3650	
Spindle taper	R-8		R-8		#40		R-8		R-8		#40	
Spindle travel	5"	125mm	5"	125mm	5"	140mm	5"	125mm	5"	125mm	5"	140mm
Spindle feed range	.0015 / .003 / .006 ipr		.0015 / .003 / .006 ipr		.0015 / .003 / .006 ipr		.0015 / .003 / .006 ipr		.0015 / .003 / .006 ipr		.0015 / .003 / .006 ipr	
Head movement side to side	±90°		±90°		±90°		±90°		±90°		±90°	
Head movement front to back	±45°		±45°		NA		±45°		±45°		NA	
<b>TABLE</b>												
Table size (W x L x H)	9"x42"x3 1/8" 230x1065x80		10"x50"x3 1/8" 255x1270x80		11"x52"x3 1/8" 280x1320x80		9"x49"x3 1/8" 230x1245x80mm		10"x50"x3 1/8" 255x1270x80		11"x52"x3 1/8" 280x1320x80	
Table feed (longitudinal)	30"	760mm	36"	915mm	32"	825mm	31"	787mm	36"	915mm	32"	825mm
Table feed (cross)	16"	405mm	16"	405mm	16"	405mm	13"	330mm	16"	405mm	16"	405mm
Table travel (knee vertical)	16.5"	420mm	18.5"	470mm	22"	560mm	16.5"	420mm	18.5"	470mm	22"	560mm
Maximum weight of workpiece	850 lbs.	386 kg	850 lbs.	386 kg	990 lbs.	450 kg	850 lbs.	386 kg	850 lbs.	386 kg	990 lbs.	450 kg
<b>OVERARM</b>												
Rotation of overarm	360°		360°		360°		360°		360°		360°	
Overarm adjustment	17 1/4"	440mm	22"	560mm	24"	610mm	15"	381mm	22"	560mm	24"	610mm
Spindle nose to table	2 1/2"-18 1/2"	65 - 470mm	2 1/2"-18 1/2"	65 - 470mm	2"-22"	50 - 560mm	0"-17 1/2"	445mm	2 1/2"-17 1/2"	65 - 445mm	2"-22"	50 - 560mm
<b>WEIGHT</b>												
	2200 lbs.	1000 kg	2900 lbs.	1320 kg	3740 lbs.	1700 kg	2,200 lbs.	1000 kg	2900 lbs.	1320 kg	3740 lbs.	1700 kg

FOR MORE INFORMATION CALL  
**1-800-654-3262**



**WARRANTY:** A copy of Summit Machine Tool Manufacturing L.L.C.'s standard written warranty is attached to each Summit Machine. Call or write to Summit for a copy or for further information concerning Summit's standard warranty. All purchases are subject to Summit's standard written warranty. Specifications are subject to change without notice.

**POINT OF OPERATION** guarding is the responsibility of the end user. For information contact your local OSHA office.

**Summit Machine Tool Manufacturing L.L.C.**

P.O. Box 1402 • Oklahoma City, OK 73101 • 405.235.2075 • FAX 405.232.5169

A Subsidiary of LSB Industries, Inc.

[www.summitmachinetool.com](http://www.summitmachinetool.com)