

Summit Machine
Tool Manufacturing
L.L.C.



Horizontal Milling Machine

#3 Series

The Summit #3 series milling machines are designed to provide extreme accuracy with high reliability in a heavily constructed versatile machine. The heavy cast iron construction makes these mills the ideal choice for job shops, maintenance shops and tool and die shops. They can be successfully used for single piece, small lot or high production applications. The large choice of spindle speeds coupled with infinitely variable feed rates provide for optimum cutting conditions in ferrous and non-ferrous metals.

A few of the outstanding design features are; an alloy steel main spindle that is thermally treated and precision ground then fixed on high accuracy bearings; a heavily proportioned saddle assembly that travels on precision ground ways that assure rigidity and stability under extreme loads; and an automatic lubrication system that ensures consistent lubrication of the spindle. Spindle speed change is easily accomplished using the clearly identified levers and charts mounted on the column or the overarm. The feed rate is infinitely variable and controlled by a potentiometer on the conveniently located control panel.

The engineering excellence, fine workmanship, quality materials and robust specifications of the Summit #3 Series Universal Horizontal Mills assures you greater production and trouble free operation for years to come.

Summit #3 Series Unive

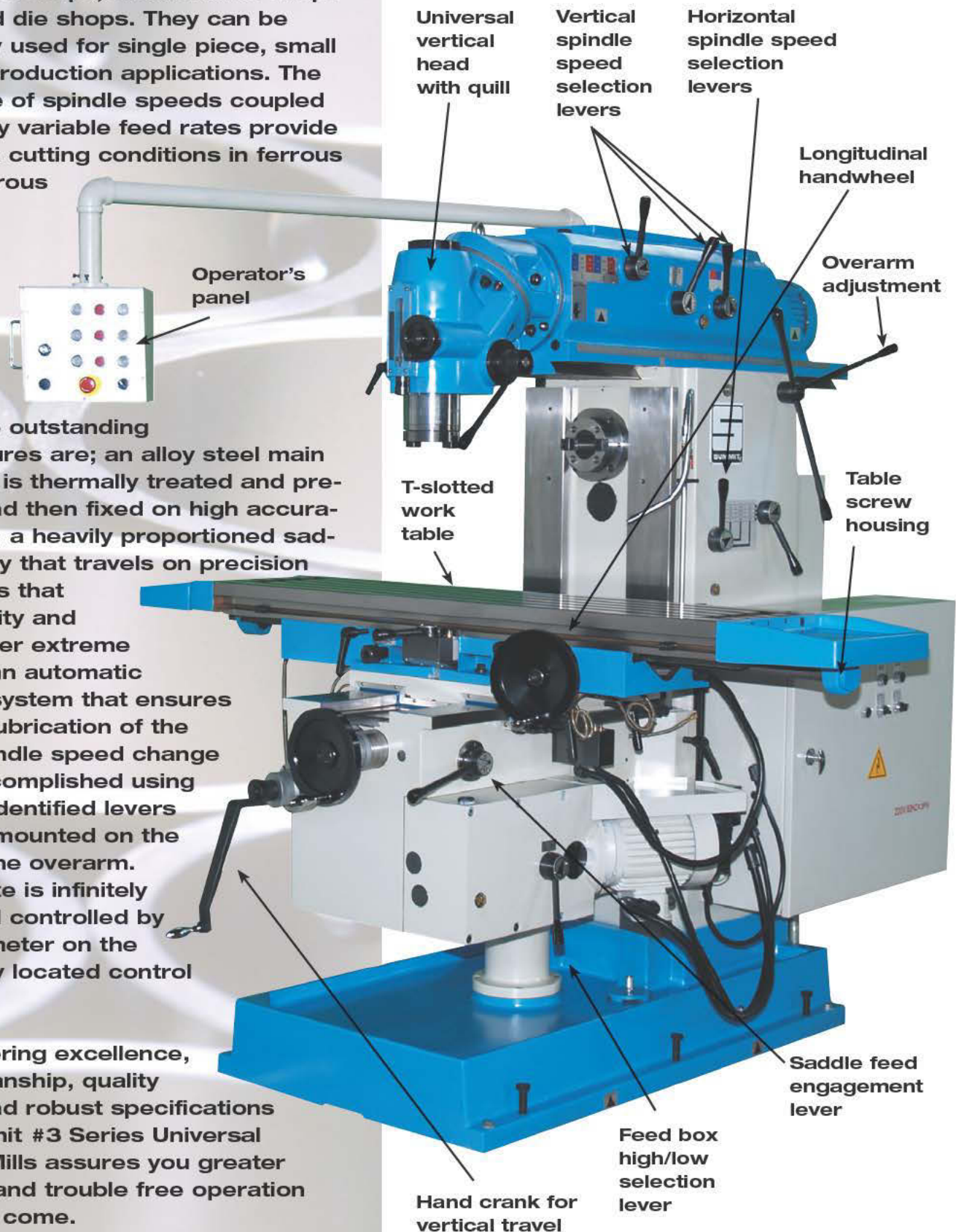

3UH-POH-Q shown

Universal Horizontal Milling Machines



Head

Three different vertical heads are available on the #3 series mills. The 3UH offers a universal head that can be fixed to and driven by the horizontal spindle; the 3UH-POA-U incorporates a universal head that is mounted to the over-arm and is driven by a separate 5.5 HP motor; the 3UH-POA-Q incorporates a universal head with a moveable quill that is mounted to the over-arm and is driven by a separate 5.5 HP motor. The addition of the vertical head allows the #3 series to be used as vertical mills adding to their versatility. The 50 taper allows you to use all of your standard tool holders in either spindle.



Knee & Column

The column is designed with box ways for vertical movement of the knee and the knee is designed with box ways for cross movement of the saddle. The ways are widely dimensioned to provide rigidity and reduce vibration. The infinitely variable feed motor and two range gearbox is mounted on the right side of the knee.



Variable Frequency Drive

The variable frequency drive enables immediate response to the infinitely variable cutting feed rates, in either the high or low range on the table, so that feed rates can be tweaked up or down during a cut to optimize tool life and part finish.



Electrical Installation

The electrical controls are located on the lower side of the column in a separate box which protects them against humidity and dust. They are easily accessible. The controls are supplied with 24 volts to meet safety standards. All electric motors are protected against overloading and short circuits.

STANDARD FEATURES

- Vertical attachment with drawbar (3UH)
- Coolant pump and piping
- Drawbar
- Backlash eliminator
- Universal table
- Set of wrenches
- Arbor supports and arbor
- 10 H.P. main motor
- 5.5 HP spindle motor (3UH-POA-U and 3UH-POA-Q)

Specifications

#3 Series Horizontal Milling Machines

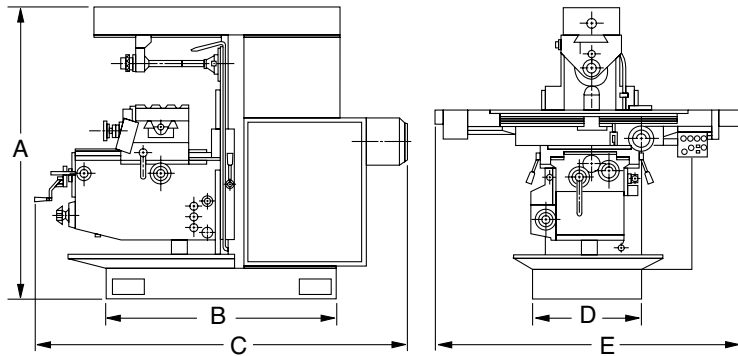

#3 Series Mills Dimensions

	3UH	3UH-POA-U	3UH-POA-Q
A*	73"	82"	82"
B	54.25"	54.25"	54.25"
C	80"	80"	80"
D	32.5"	32.5"	32.5"
E	138"	138"	138"

*Height including pendant arm.
(All dimensions are approximate for reference only)

SPECIFICATIONS	3UH-POA-Q		3UH-POA-U		3UH	
	Inch	Metric	Inch	Metric	Inch	Metric
TABLE						
Working surface	13.7" x 59"	350 x 1500mm	13.7" x 59"	350 x 1500mm	13.7" x 59"	350 x 1500mm
Swivel of table (L to R)	+/-45 degrees		+/-45 degrees		+/-45 degrees	
CAPACITIES						
Longitudinal travel	46"	1170 mm	46"	1170mm	46"	1170mm
Cross travel	15 3/4"	400mm	15 3/4"	400mm	15 3/4"	400mm
Vertical travel	20"	500mm	20"	500mm	20"	500mm
Quill travel	4"	100mm	N/A	100mm	N/A	N/A
Column to table center (min to max)	7" - 22 3/4"	175mm - 575mm	7" - 22 3/4"	175mm - 575mm	7" - 22 3/4"	175mm - 575mm
Spindle to table (min to max)	1" - 20"	25-500mm	1" - 20"	25-500mm	1" - 20"	25-500mm
HORIZONTAL SPINDLE						
Taper	#50		#50		#50	
Speeds no.	12		12		12	
Speeds range	48 - 2160 RPM		48 - 2160 RPM		48 - 2160 RPM	
VERTICAL SPINDLE (POWER OVER ARM)						
Taper	#50		#50		N/A	
Speeds no.	12		12		N/A	
Speeds range	40 - 1860 RPM		40 - 1860 RPM		N/A	
FEEDS						
Number	Infinitely Variable		Infinitely Variable		Infinitely Variable	
Longitudinal	.4 - 47 IPM	10 - 1200mm/min	.4 - 47 IPM	10 - 1200mm/min	.4 - 47 IPM	10 - 1200mm/min
Cross travel	.4 - 47 IPM	10 - 1200mm/min	.4 - 47 IPM	10 - 1200mm/min	.4 - 47 IPM	10 - 1200mm/min
Vertical travel	.2 - 23 IPM	5 - 600mm/min	.2 - 23 IPM	5 - 600mm/min	.2 - 23 IPM	5 - 600mm/min
Rapid traverse	47 IPM	1200mm/min	47 IPM	1200mm/min	47 IPM	1200mm/min
MOTORS						
Main motor	10 HP	7.5 kw	10 HP	7.5 kw	10 HP	7.5 kw
Over arm	5.5 HP	4 kw	5.5 HP	4 kw	N/A	N/A
Feed motor	2 HP	1.5 kw	2 HP	1.5 kw	2 HP	1.5 kw
Coolant pump	.1 HP	.075 kw	.1 HP	.075 kw	.1 HP	.075 kw
WEIGHT	7040 lbs.	3200 kg	7040 lbs.	3200 kg	6820 lbs.	3100 kg

FOR MORE INFORMATION CALL
1-800-654-3262



WARRANTY: A copy of Summit Machine Tool Manufacturing L.L.C.'s standard written warranty is attached to each Summit Machine. Call or write to Summit for a copy or for further information concerning Summit's standard warranty. All purchases are subject to Summit's standard written warranty. Specifications are subject to change without notice.

POINT OF OPERATION guarding is the responsibility of the end user. For information contact your local OSHA office.

Summit Machine Tool Manufacturing L.L.C.

P.O. Box 1402 • Oklahoma City, OK 73101 • 405.235.2075 • FAX 405.232.5169

A Subsidiary of LSB Industries, Inc.

www.summitmachinetool.com