

SUMMIT
MACHINE TOOL LLC

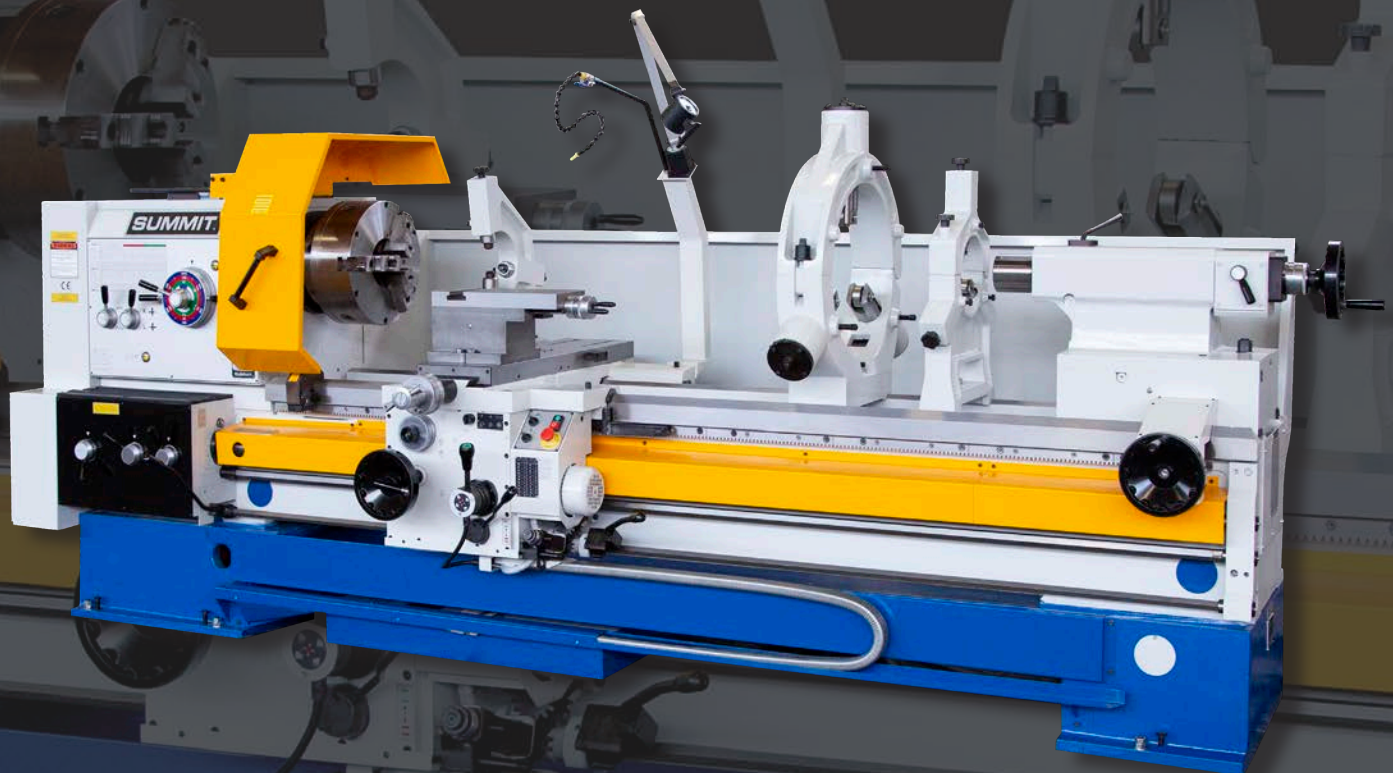

PRECISION METAL LATHES

30-5 SERIES

PRECISION METAL LATHES

30-5 SERIES

The **Summit 30-5"** Lathes combine accuracy, simplicity and affordability to bring you a proven industry leader. Tested under the most demanding work conditions, the Summit 30-5" turns rings around other lathes in their class.

These lathes have just the right amount of engineering to afford simplicity of operation, coupled with plain and simple rugged reliability. In addition, built in safety features like the safety clutch in the apron that kicks out the feed and the feed/threading safety interlock eliminating the simultaneous engagement of the feed and threading motion, place these machines in a field of their own — unparalleled in performance.

A few of the outstanding features of the 30-5" lathes are a cross ribbed headstock for added strength and stability, with anti-friction mounted shafts and dynamically balanced components; hardened and ground alloy steel gears, shafts and splines, and an oversized precision chrome alloy spindle with a big 5.1" thru hole that is mounted in double row angular contact thrust bearings and 2 double row roller bearings. These large spindle bearings give the 30-5" greater radial and thrust capacities ensuring very precise turning capabilities.

Available in 80", 120", 160", and 200" center distances, these lathes have 29.9" swing over the bed, and a 20.5" swing over the cross slide. They also feature hardened and precision ground bedways on a heavy one-piece closed grain cast bed that is fully ribbed for maximum stability and even thermal expansion. Standard on every machine is a quick-change gearbox for cutting Metric, Module and Diametral Pitch threads as well as standard American threads.

The engineering excellence, fine workmanship, materials and impressive specifications of the Summit Lathes assure you of greater production and easy, trouble free operation for years to come.

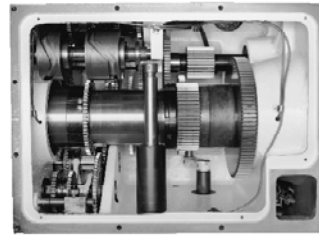

Headstock

Fully geared headstock provides 17 spindle speeds through precise, hardened and ground gears. Each gear is thoroughly tested for accurate tooth configuration and flank engagement to assure optimum quiet and smooth running, and is precision fitted on hardened and ground splined shafts for ease of speed selection. All shafts are mounted in ball or tapered roller bearings. Spindle drive is achieved through mechanical "multi-disc" clutches for forward, and reverse rotation.



"Thru Hole"

Spindle is precision machined, hardened and ground from a massive one-piece forging. It features a full 5.1" thru hole, enabling large work pieces to be introduced without excessive overhang. The spindle is mounted in precision angular contact thrust bearings for accuracy and smooth running, and is supported by large diameter precision roller bearings for stability. Chuck mounting is standard D1-11 camlock and a reduction sleeve is provided to facilitate use of Morse taper tooling.

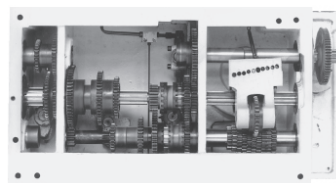

Norton Control Box

Totally enclosed, quick change feed gearbox allows easy selection of most standard and metric threads and feeds without use of change gears. All gears and splined shafts are of hardened and ground alloy steel, precision fitted for ease of shifting and mounted in high precision anti-friction bearings. The feed gearbox assembly is oil bath lubricated for smooth operation and quiet running.

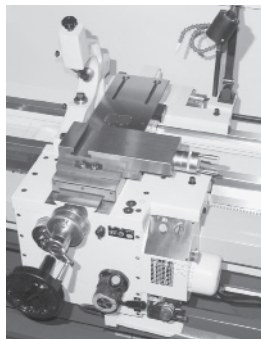
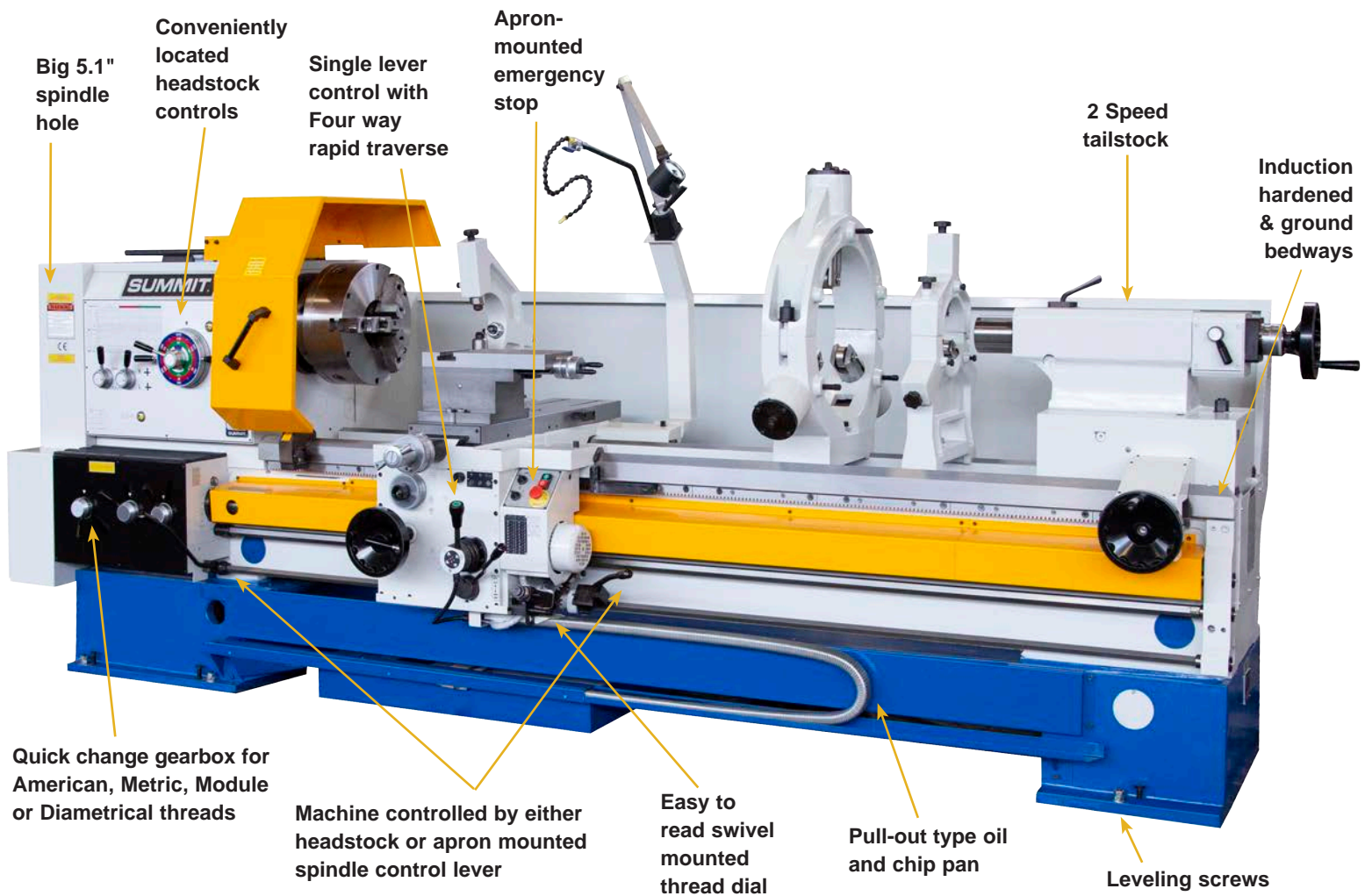

Carriage

Carriage assembly features extended cross slide for accommodation of special tooling, tracer attachments, etc. The cross slide is constructed of high quality cast iron and incorporates externally adjustable nuts to provide for backlash elimination. The rugged, heavy duty taper attachment is capable of generating tapers of ± 10 degrees up to 17.7" long and is graduated in degrees for convenience of operation.



Bedway

The bed is constructed of high grade, heavy duty 22" wide bed, alloyed cast iron, normalized and aged to achieve maximum stability. The design features heavy cross ribbing for rigidity and vibration dampening and utilizes hardened and ground, bedways. The bedway design is of the double vee, 60 degree opposed style (most commonly described as the "LeBlond Profile"), affording extended accuracy and long machine life.

DIMENSIONS AND SPECIFICATIONS

30-5 PRECISION METAL LATHES



SPECIFICATIONS

30-5

CAPACITIES	INCH	METRIC
Swing Over Bed	29.9"	760 mm
Swing Over Cross Slide	20.5"	520 mm

HEADSTOCK

Spindle Bore	5.1"	130 mm
Spindle Speeds - number	17	
Spindle Speeds - range	7.5 - 1015 RPM	
Headstock Reducer	#6 MT	
Spindle Nose	D1 - 11 Camlock	

FEEDS & THREADS

Threads per inch - (no.) range	(76) / 1-6 - 60	
Metric Threads - (no.) range	(76) .5 - 180	
Longitudinal Feeds - (no.) range	(150) .00145 - .66816 IPR	
Cross Feeds - (no.) range	(150) .0007 - .33408 IPR	
Leadscrew - (diameter) range	(2") 2 TPI	

CARRIAGE & APRON

Cross Slide Travel	16.1"	410 mm
Compound Travel	5.9"	150

TAPER ATTACHMENT

Degrees of Taper	+/- 10 degrees	+/- 10 degrees
Length of Taper Per Setting	17.7"	450 mm

BED

Width of Bed	22"	560 mm
Bed Way Hardness (Rockwell C)	42 - 48	

TAILSTOCK

Travel of Spindle Barrel	8.8"	225 mm
Diameter of Spindle Barrel	4.1"	105 mm
Taper of Center	#6 MT	

MOTORS

Main Drive motor	25 HP	
Coolant Pump	1/8 HP	

MISCELLANEOUS

Width x Height	60" x 70"	1525 x 1780 mm
Length x Width - 80"	144" / 10,780 lbs.	3,660mm / 4,900 kg
Length x Width - 120"	184" / 12,100 lbs.	4,675mm / 5,490 kg
Length x Width - 160"	224" / 14,100 lbs.	5,690mm / 6,400 kg
Length x Width - 200"	284" / 16,500 lbs.	7,215mm / 7,485 kg

STANDARD FEATURES

- Big 5.1" thru hole
- Inch/metric threads w/single switch lever
- Cuts most inch/metric threads without change gears
- Hardened & ground bedways
- Force lubrication to the headstock, carriage and bedways
- Mechanical disc clutch
- Precision (3) bearing spindle
- Crossfeed and threading safety interlock
- Feed reversing at the apron
- 4-way rapid traverse
- Single lever control for feeds and rapids
- Two speed tailstock

INCLUDED ACCESSORIES

- Standard Steady Rest
- Extra Capacity Steady Rest w/ Rollers
- Follow Rest
- Thread Dial
- Coolant System
- Taper Attachment
- 16" 3 Jaw Chuck w/Solid Jaws
- Carriage Stop
- Work Light
- Full Length Splash Guard
- Service Wrenches & Spanners

WARRANTY: A copy of Summit Machine Tool LLC's standard written warranty is attached to each Summit Machine. Call or write to Summit for a copy or for further information concerning Summit's standard warranty. All purchases are subject to Summit's standard written warranty. Specifications are subject to change without notice.

POINT OF OPERATION GUARDING is the responsibility of the end user. For information contact your local OSHA office.

03/2023

SUMMIT MACHINE TOOL LLC

518 N Indiana Ave • Oklahoma City, OK 73106

MAIN 405.235.2075

FAX 405.232.5169



FOR MORE INFORMATION CALL 1-800-654-3262

WWW.SUMMITMACHINETOOL.COM